

MANUFACTURING OF BOXES FOR LITHIUM-ION BATTERIES

We manufacture durable battery boxes with custom-designed and engineered solutions for lithium-ion battery systems. Our designs ensure high safety, impact resistance, and long-lasting performance, providing reliable protection for your batteries.

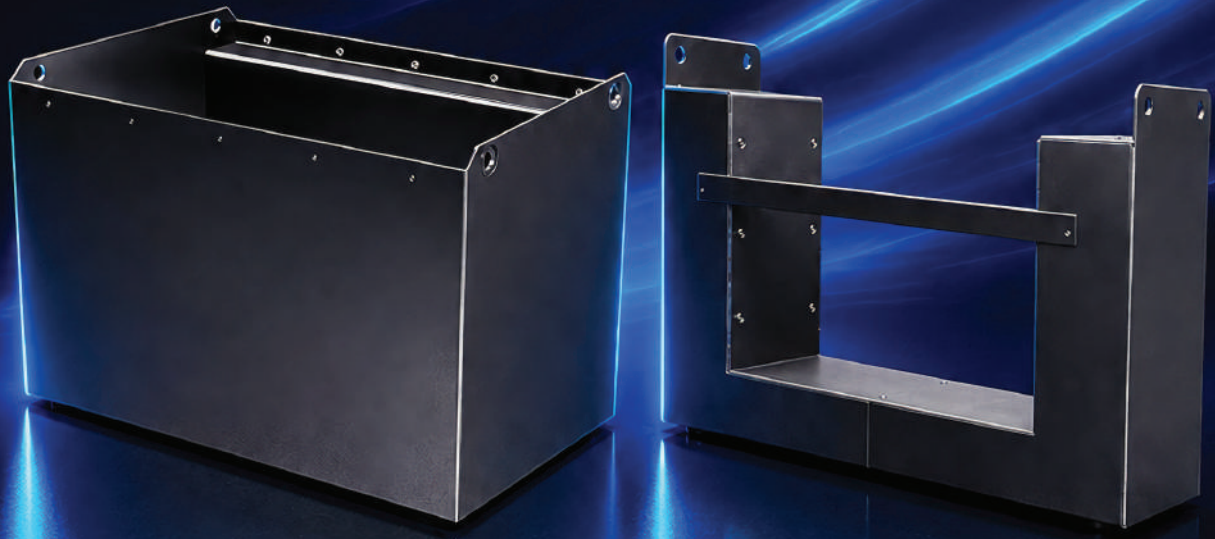

GÖKSUN
POWERBOX

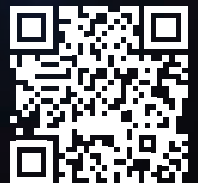



ROBUST PROTECTION, SECURE ENERGY SYSTEMS

We manufacture high-strength, safe, and long-lasting box solutions for lithium-ion battery technologies. Our custom designs, developed to meet industrial application requirements, combine maximum protection, high strength, and an aesthetic approach to manufacturing.

Our lithium-ion battery boxes, manufactured with project-specific dimensions and engineering support, offer superior resistance to impacts, vibrations, temperature fluctuations, and harsh operating conditions. Thanks to our modern production infrastructure, we provide customized solutions tailored to the needs of various industries.

APPLICATIONS

- ✓ **Pallet jack and forklift battery cases**
- ✓ **Custom housing solutions for AGV/AMR systems**
- ✓ **Industrial boxes for energy storage systems**
- ✓ **Manufacturing of protective boxes for telecommunications and UPS systems**
- ✓ **Custom designs for solar and mobile energy systems**
- ✓ **Lithium-ion battery boxes for rail systems and logistics applications**

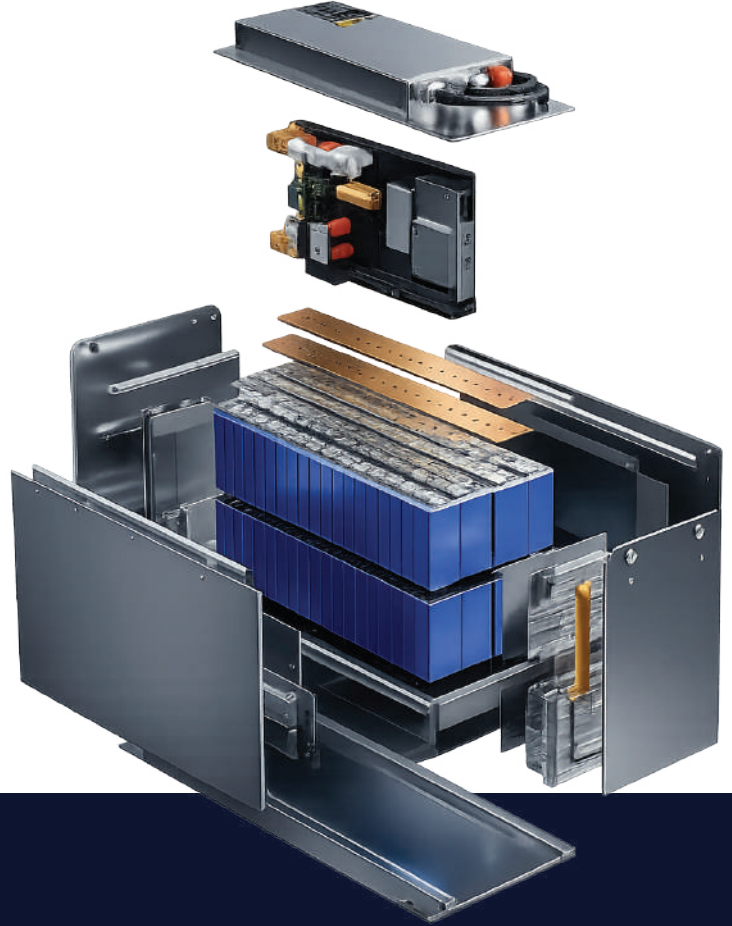

High-strength steel structure



Custom sizing and manufacturing



Heat- and impact-resistant construction



Long service life for industrial use



Design optimized for safe use



Electrostatic industrial powder coating



goksunas.com.tr

+90 (312) 815 14 87

info@goksunas.com.tr

GÖKSUN
POWERBOX



LITHIUM-ION BATTERY BOX SOLUTIONS

The box solutions we have developed for lithium-ion battery systems combine safety, durability, and functionality in a single design. By adhering to high-quality standards in every project, we provide services based on a commitment to long-lasting and reliable production.

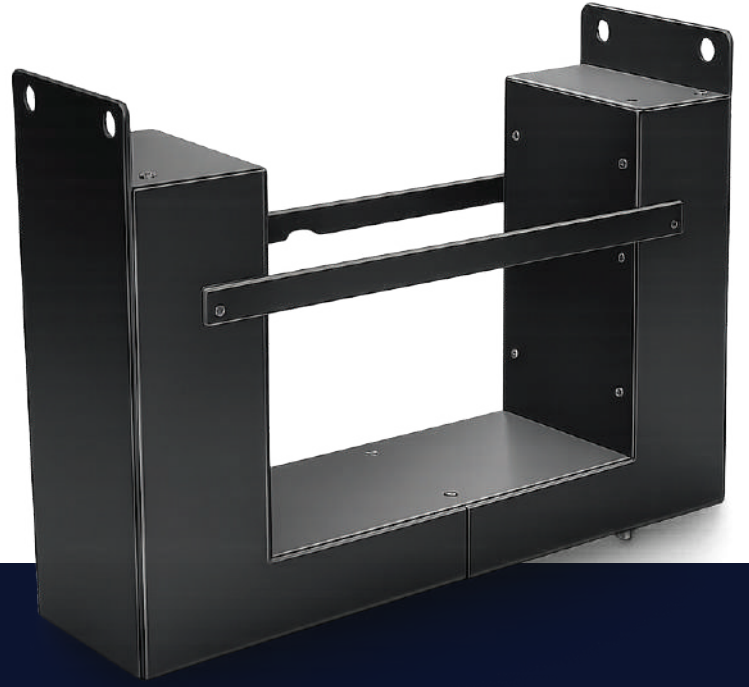

PRODUCT FEATURES



High-Strength Steel Construction

Its robust construction, designed for heavy-duty industrial conditions, ensures long-term durability.



Heat and Impact Resistance

It reliably protects battery systems from external factors in demanding work environments.



Security-Focused Design

It offers engineering solutions optimized for battery safety and system integrity.



Custom Manufacturing

Production can be customized to meet specific needs, including custom dimensions, connection configurations, and internal layout options.



Suitable for Industrial Use

It delivers maximum performance and durability in industries that demand heavy-duty use.



Electrostatic Powder Coating

It provides high-level surface protection against corrosion, wear, and environmental factors.

WITH OUR HIGH-QUALITY AND SAFE PRODUCTS THAT MEET INTERNATIONAL STANDARDS, WE ARE THE LEADING SUPPLIER TO EXPORT COMPANIES...



RELIABLE INDUSTRIAL SOLUTIONS

With our modern production infrastructure and engineering-focused approach, we manufacture durable, safe, and high-performance battery boxes for industrial battery systems. Quality, safety, and longevity are our top priorities in every project.



goksunas.com.tr

+90 (312) 815 14 87

info@goksunas.com.tr

GÖKSUN
POWERBOX

DURABLE AND RELIABLE SOLUTIONS FOR TRACTOR BATTERY BOXES

Traction batteries are widely used in forklifts, warehouse systems, and industrial transport vehicles. We manufacture high-strength, long-lasting, and safe battery cases for the batteries used in these systems.



GÖKSUN
POWERBOX





ROBUST PROTECTION AND LONG-LASTING PERFORMANCE IN TRACTION BATTERY BOXES

We manufacture high-performance, safe, and long-lasting battery boxes for traction batteries used in industrial vehicles and energy systems. Designed to withstand harsh operating conditions, our solutions combine durability, functionality, and safety.

APPLICATIONS

- ✓ **Battery-powered pallet trucks and forklift systems**
- ✓ **Floor cleaning and industrial cleaning machines**
- ✓ **Personnel lifts and platform systems**
- ✓ **Reach trucks and specialized handling equipment**
- ✓ **Airport vehicles and specialized equipment**
- ✓ **Energy storage systems in base and power stations**



High-strength steel structure



Acid-resistant thermoplastic coating



Long-lasting and safe for daily use



Production suitable for demanding working conditions



Custom sizing and design options for the project



goksunas.com.tr

+90 (312) 815 14 87

info@goksunas.com.tr

GÖKSUN
POWERBOX



TRACTION BATTERY SYSTEMS

Battery boxes play a critical role in ensuring the safe and long-lasting operation of these systems. The battery boxes we manufacture protect the battery from impact, vibration, and external factors, ensuring maximum performance and operational continuity.

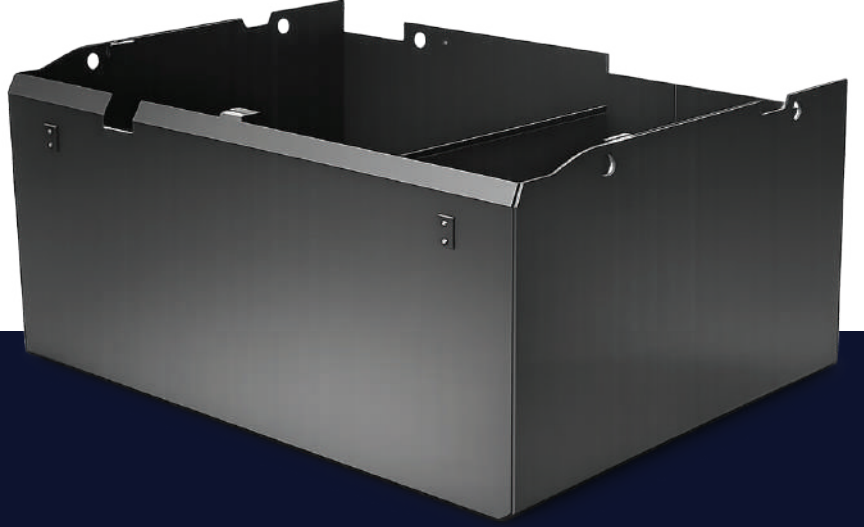

PRODUCT FEATURES



High-Strength Body Structure

Thanks to its sturdy steel construction, it offers superior resistance to impacts, vibrations, and heavy use.



Custom Manufacturing

It offers custom manufacturing options with various sizes, connection types, and internal layouts to meet specific needs.



Designed for Harsh Conditions

It is optimized for safe use in heavy industry, warehouse, and field environments.



Long-Lasting Use

Thanks to its high-quality construction and protective surface treatments, it offers a long service life.



Acid-Resistant Coating

It offers high protection against chemical exposure and corrosion thanks to its special thermoplastic coating system.

FOCUSING ON EXPORTS BRINGS PRESTIGE...

RELIABLE INDUSTRIAL SOLUTIONS

With our modern production infrastructure and engineering-focused approach, we manufacture durable, safe, and high-performance battery boxes for industrial battery systems. Quality, safety, and longevity are our top priorities in every project.



goksunas.com.tr

+90 (312) 815 14 87

info@goksunas.com.tr

GÖKSUN
POWERBOX



20+
years of
manufacturing
experience

ROBUST ENGINEERING AND RELIABLE SOLUTIONS IN BATTERY BOX MANUFACTURING

Our company is an engineering-focused manufacturer of high-strength battery boxes for lithium-ion and traction battery systems. Safety, durability, and long-term reliability are our top priorities in our manufacturing processes.



goksunas.com.tr

+90 (312) 815 14 87

info@goksunas.com.tr

GÖKSUN
POWERBOX

GÖKSUN
POWERBOX



+90 (312) 815 14 87
goksunas.com.tr

Mustafa Kemal Mah. Kayı Cad. No:68 Sincan / ANKARA
info@goksunas.com.tr